

# X SERIES

*your decision for:*



**Innovation design**

**Variety of alternatives**

**Suitable size and capacity**

**Easy to run**

**Long life**

**Mechanical reliability**

ø 34 mm ø 40 mm	M 27 M 33	1,5 Kw 2,2 Kw	MT 4 MT 4	150 mm 180 mm	ø 125 mm ø 150 mm	300 mm 350 mm



With rotating table plate and tilting support (MGI).

With reversible tiltable with vice (MGM).

With co-ordinate cross table (MCC).

## || STANDARD EQUIPMENT

- Hardened and ground high quality steel gears
- Speed plate and selecting levers on head front.
- Depth scale and adjustable depth stop
- Automatic tool ejector
- Emergency STOP push button
- Spindle reversing switch
- Electric equipment integrated on machine's head
- Machined base with coolant tank
- Worklight
- MF: Fixed table for model 34
- MGI: Rotating and tilting table for model 40
- Safety drill guard with microswitch
- CE mark

## || OPTIONAL EQUIPMENT

- MGI** Rotating table and tilting support (only for 34 models)
- MGM** Reversible tiltable with vice (only for X-34 model)
- MCC** Co-ordinate table over support
- RS** Automatic feed reversing system for tapping
- RPF** Pitch controlled tapping with braking system by speed inverter
- HGP-S** Special master guide spindle and nut set
- ACNL** Pneumatic counterbalance with rapid approach and retract (only for BX models)
- CI** Integral drilling cycle with encoder (only for BX models)
- HB** Hidroblock automatic feed system
- UC** Union, dragging cone and assembly for multi-spindle head
- GM** Multi-spindle head guide rod
- PM** START/STOP/EMERGENCY control extensión (only for BX models)
- SC** Column riser (200 mm)

# X SERIES

## Round column - Gear Transmission

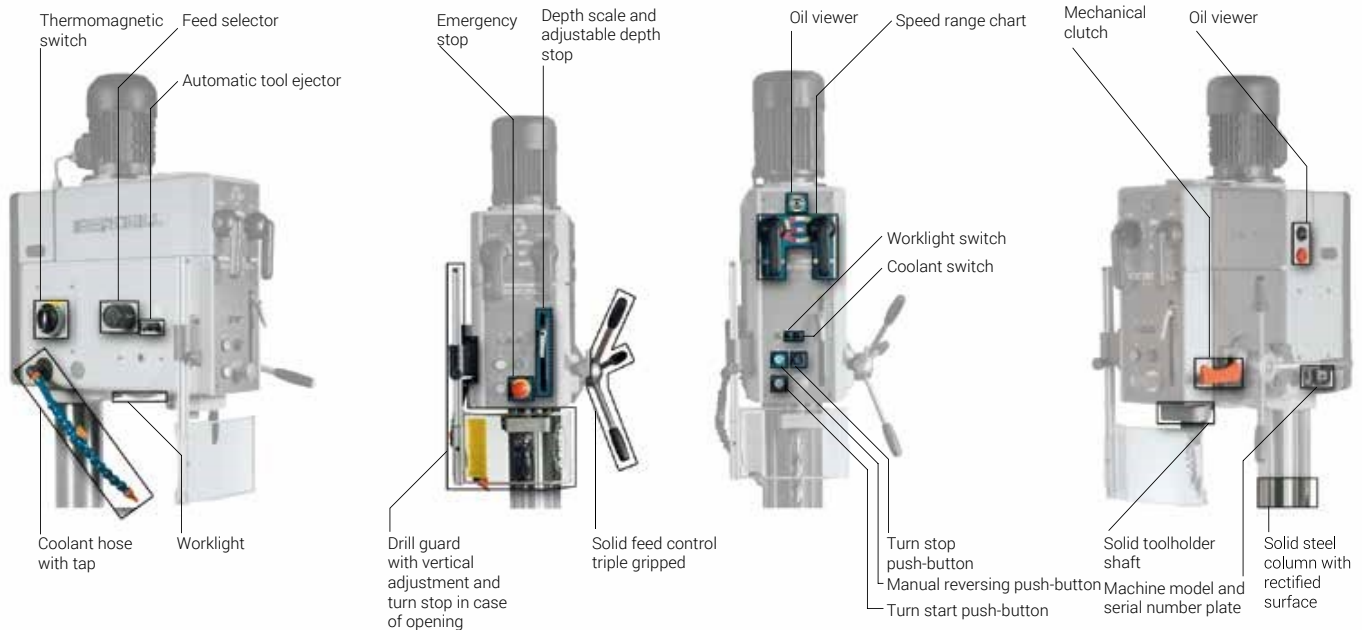

### || CHARACTERISTICS

### SX-34 AX-34 BX-34 SX-40 AX-40 BX-40

Maximum drilling capacity in steel St. 50/60	[ø mm]	34			40		
Maximum drilling capacity in cast iron 200 Brinell	[ø mm]	40			45		
Maximum tapping capacity in steel St. 50/60	[mm]	M 27			M 33		
Maximum tapping capacity in cast iron 200 Brinell	[mm]	M 33			M 39		
Morse Taper MT	[Nr.]	4					
Maximum spindle stroke (drilling depth)	[mm]	150			180		
Main motor power	[HP (Kw)]	2 (1,5)			3 (2,2)		
Coolant pump motor power	[HP (Kw)]	0,10 (0,07)					
Transmission		Gear box					
Number of speeds		9					
Speed range with motor at 1500 rpm 50 Hz 3Ph. Upon request: Motor at 1800 rpm 60 Hz 3Ph. (160-2220 rpm)	[rpm]	132-194-277-319-466-666-883-1296-1852					
Feed		Manual	Automatic		Manual	Automatic	
Nr. of automatic feeds		-	3		-	3	
Automatic feed range	[mm/rev]	-	0,1-0,2-0,3		-	0,1-0,2-0,3	
Worktable dimensions (LxW).	[mm]	400x420			480x480		
Column diameter	[mm]	125			150		
Distance from spindle centre to column face	[mm]	300			350		
Net weight	[Kg]	385	400	410	475	490	500
Gross weight with packing	[Kg]	435	450	460	525	540	550
Packing dimensions (length x width x height)	[m]	2,3x0,6x1,1					